

VALVE GEARS

BY

CHARLES H. FESSENDEN, M. E.

PROFESSOR OF MECHANICAL ENGINEERING, UNIVERSITY OF MICHIGAN

FIRST EDITION

FOURTH IMPRESSION

McGRAW-HILL BOOK COMPANY, INC.

NEW YORK: 370 SEVENTH AVENUE

LONDON: 6 & 8 BOUVERIE ST., E. C. 4

1915

CHAPTER XI

REVERSING GEARS

Engines which must be reversed in direction of rotation, frequently, on account of their particular application must be equipped with some form of valve gear which will permit this being done easily by the operator. Among the most common gears of this kind may be mentioned:

1. The Stephenson Link Motion.
2. The Walschaert Valve Gear.
3. The Joy Valve Gear.

Besides providing a means of reversing the engines at will, these gears also permit the cut-off to be varied by the operator while the engine is running.

The Stephenson Link Motion.—In past years the Stephenson link motion (invented in 1843) received more attention in this country than the other gears mentioned and was extensively used on hoisting engines, marine engines, and especially on locomotives. Until about 1904, practically all the locomotives in the United States were equipped with this gear.

Possibly the idea of the Stephenson link motion grew out of the fact that an engine can be reversed by shifting the eccentric from position Od (Fig. 131) to position Od' . If a disk with a slot dd' is keyed to the end of the shaft and the end of the eccentric rod is fitted with a block which can be slid along the slot dd' and secured at any desired point, the angular position and the length of the eccentric arm can be changed at will. Thus the eccentricity might be Od , Od'' , or Od' . When the eccentric radius is in the neighborhood of Od'' the angle of advance is greater and the eccentricity less than Od and an earlier cut-off is obtained; a shift past the point d''' would reverse the engine.

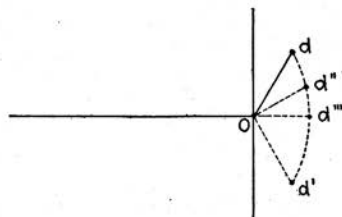

Fig. 131.

The practical mechanism, incorporating the general ideas expressed above, is shown diagrammatically in Fig. 132. It

will be noted that the link between the two eccentrics has been moved away from the shaft, O , and that eccentric rods have been inserted. The link can be shifted by means of a bell crank lever so that d or d' or any intermediate point along the link will stand opposite the block b in the end of the valve rod. The arm by which the link is shifted is at one side of the link, thus allowing the latter to swing in the plane of motion of the valve. If the link is shifted downward so that d is opposite the block, the valve will receive motion from eccentric Oe alone; if the link is shifted to the other extreme position so that d' is opposite the block the valve will receive motion from eccentric

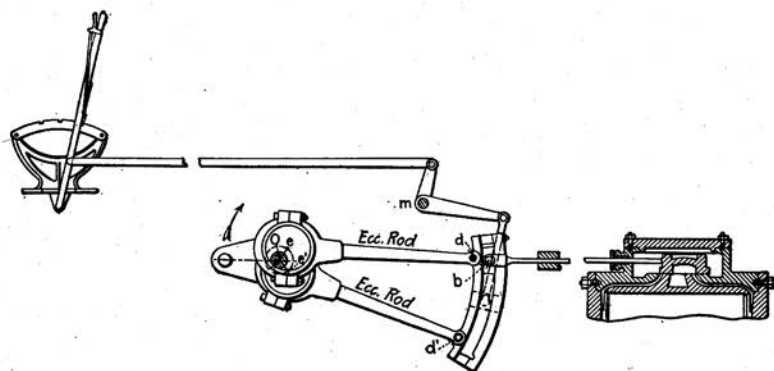

FIG. 132.—Stephenson link mechanism.

Oe' alone; but for any position of the link between these two extremes the valve will receive motion from a virtual or equivalent eccentric whose angular position is somewhere between Oe and Oe' , and whose radius is something less than Oe .

Locomotives have two engines with cranks at right angles, and each valve gear is provided with a link. Both links are shifted simultaneously by means of a lever in the cab which rotates the shaft m .

When the link is in such a position that d (Fig. 132) is in line with b it is said to be in *full gear ahead*; when in such a position that d' is in line with b it is in *full gear back*. When b is half way between d and d' the link is in *mid gear*. Shifting the link from the full gear toward the mid-gear position is termed *notching up* or *hooking up*. Positions intermediate between mid gear and full gear are expressed in fractions of the shift from mid to full gear. The mechanism is made

so that the lever on the notched arc in the cab is relatively in the same position as the block in the link.

When starting the engine the link should first be thrown into the full-gear position so that a late cut-off will be obtained; then with the throttle partly open a powerful, steady force will be exerted on the drivers. As the inertia is gradually overcome and the engine increases in speed the link should be hooked up to give an earlier cut-off and better steam distribution.

It is necessary to distinguish between two possible arrangements of the eccentric rods. If the rods stand clear of each other when the eccentrics are between the link and the

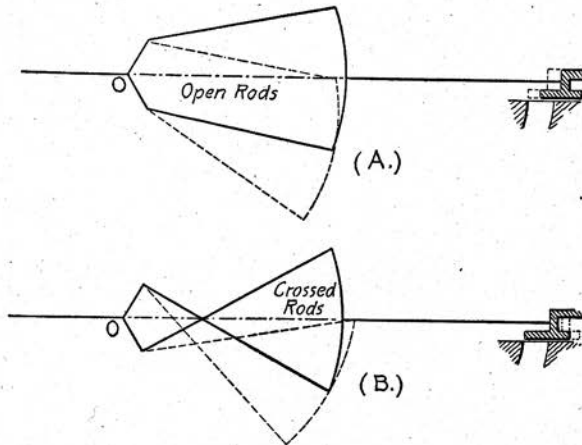

FIG. 133.—Open rods and crossed rods and their effect on lead.

vertical through O , as shown in Figs. 132 and 133(A), they are called *open rods*. If they stand as shown in Fig. 133(B) they are called *crossed rods*. The most important difference in these two arrangements of rods is the effect on the lead when the link is shifted. With open rods, shifting the link from mid-gear to full-gear position decreases the lead as shown in Fig. 133(A). Fig. 133(B) shows the opposite effect for crossed rods. The amount of variation of lead from mid to full gear depends on the radius of curvature of the link and is increased as the radius is decreased.

Approximate Layout.—A convenient method of obtaining the approximate solution of link motion problems is by means of what is known as an *equivalent* or *virtual eccentric*. An *equivalent eccentric* is an imaginary eccentric which, if used, would give

nearly the same movement to the valve as the more complicated gear. The following method of finding the equivalent eccentric is often used for open rods; a similar method can be used for crossed rods, but as crossed rods are seldom used that construction will not be discussed here.

The point of cut-off when in full gear should be chosen at about 85% of the stroke and the valve allowed to overtravel the port about one-fourth of the width of the port. A lead of $1/16''$ may be assumed. Construct a Bilgram diagram to determine the length of the equivalent eccentric and its angle of advance for latest cut-off.

The general proportions of the engine on which the link motion is placed usually determine the length of the eccentric rods. The distance from the center of the eccentric to the center

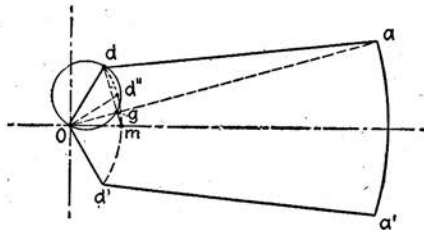

FIG. 134.—Graphical determination of equivalent eccentric for open rods.

of the link arc, measured along the eccentric rod, is usually taken for the radius of the center of the link arc.

Having decided upon the general proportions of the gear, a skeleton diagram can be laid out as shown in Fig. 134, with the equivalent eccentric for full gear represented by Od and Od' . On Od as a diameter construct a circle and by drawing Oa and dgm through the intersection point, g , locate the point m on the axis line. Through d , m , and d' draw a circular arc; this will give the locus of all equivalent eccentrics for various link positions. When the link is in half gear it will give a motion to the valve which is approximately the same as the motion which it would receive from a single eccentric Od'' , where d'' is half way between d and m . Od'' represents the equivalent eccentric, both in radius and angular position. When the link is in mid-gear the motion of the valve will be approximately the same as it would receive from an equivalent eccentric Om .

The equivalent eccentric being known, the motion of the valve may be analyzed for any assumed position of the link as in the case of a simple gear, but it must be remembered that this method gives results which are only approximately correct.

The Walschaert Valve Gear.—The *Walschaert* valve gear belongs to the general class known as *radial gears*. In this class

are included a number of mechanisms which give practically harmonic motion to the valve and enable the steam distribution and the direction of rotation to be altered.

A Swiss named Egide Walschaerts invented the Walschaert gear in 1844 so that it is about as old as the Stephenson link motion. For many years it has been used on locomotives in continental Europe but was almost unknown in this country until after 1900. The American Locomotive Company is now equipping nearly all of its locomotives with the Walschaert gear for the following reasons:

In modern locomotives the use of an outside valve gear is practically necessary, because with the weight and power of the

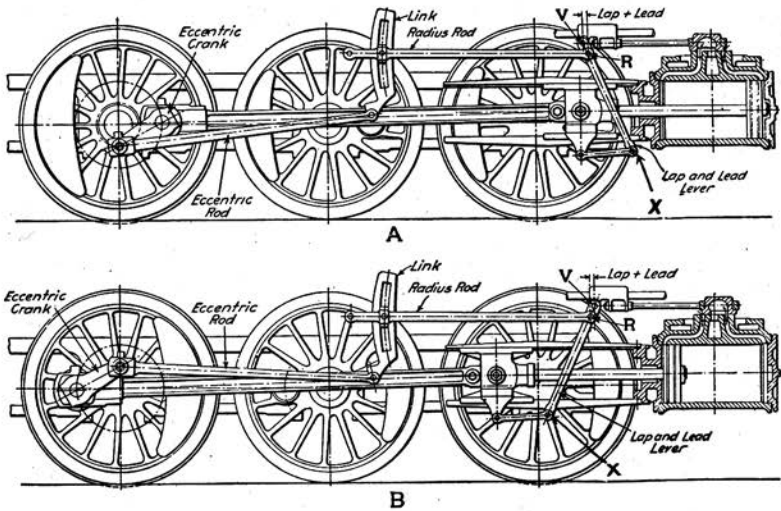

Fig. 135.—Walschaert valve gear.

locomotives of today it is almost impossible to get a satisfactory design of Stephenson link motion between the frames. The parts are necessarily so large that there is hardly room for them. With the Walschaert valve gear, which is outside of the frames, this difficulty is overcome.

In the modern locomotive the eccentrics and straps of the Stephenson link motion are necessarily very heavy and wide. The rubbing speed is consequently high and results in rapid wear. This, in combination with the rockers and transmission bars, permits the accumulation of a great amount of lost motion in the

gear. With the Walschaert valve gear there are no large eccentrics, only hardened pins and bushings. As a result it is much more easily maintained than the Stephenson mechanism.

Being located outside of the frames, the Walschaert gear is easily accessible for proper lubrication and attention by the engineer.

By removing the valve gear from between the frames a better opportunity is afforded to introduce stronger frame bracing, thus reducing the possibility of frame failure.

Fig. 135 shows the arrangement of the parts which make up the Walschaert gear. Two positions of the mechanism are shown, *A* for admitting steam at the forward end, and *B* for admitting steam at the back end. Fig. 136 is a skeleton diagram of the gear. The *link* is trunnioned at its middle point and rocked by means of an *eccentric rod* whose motion is derived from an *eccentric crank* secured to the main crank pin. The movement of the link is transmitted

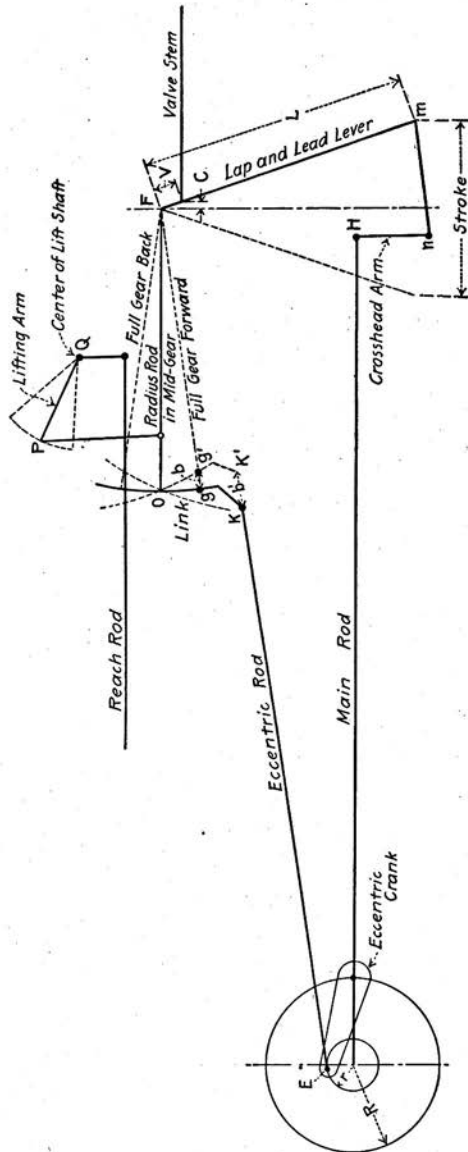

FIG. 136.—Skeleton diagram of Walschaert valve gear.

to the *link* is transmitted

to the valve stem by a *radius rod* whose length is equal to the radius of curvature of the link. Pinned to the radius rod is a block which slides in the link when the radius rod is raised or lowered by the engineer. When the block is above the link fulcrum the engine runs in one direction, and when below the fulcrum the engine runs in the opposite direction.

The eccentric crank is so set that, when the engine is on either dead center the link stands in its middle position and if the radius rod were attached directly to the valve stem, the valve would also be in its mid-position regardless of whether the block were up or down in the link. However, when the piston is at the end of its stroke the valve should be displaced from its mid-position by an amount equal to the lap plus the lead. In the Walschaert gear this is accomplished by the use of a lever, called the *lap and lead lever*, which is attached to both the valve stem and the radius rod and is also connected, through a suitable rod, to the crosshead. This lap and lead lever is so proportioned that if the point of its connection to the radius rod be kept a stationary fulcrum and the engine piston moved a distance equal to the stroke the valve will be moved a distance equal to twice the lap and lead. When the piston is at the end of its stroke the valve is displaced from its mid-position a distance equal to the lap plus the lead. Inasmuch as the position of the valve, when the piston is at the end of its stroke, is dependent on the lap and lead lever alone, it is evident that the *lead* given by the Walschaert gear is the same for all points of cut-off.

There are two arrangements of the Walschaert gear, depending on whether it is to be used with outside admission or inside admission valves. With a valve having *outside* admission the valve stem is connected to the lap and lead lever at a point *above* the latter's connection to the radius rod (see Fig. 135). If the block is in the *lower* half of the link when in forward gear, the eccentric crank *leads* the main pin. If the block is in the *upper* half of the link when in forward gear, the eccentric crank *follows* the main pin.

With a valve having *inside* admission the valve stem is connected to the lap and lead lever at a point *below* the latter's connection to the radius rod (see Fig. 136). If the block is in the *lower* half of the link when in forward gear the eccentric crank *follows* the main pin. If the block is in the *upper* half of the link when in forward gear, the eccentric crank *leads* the main pin.

The diagrams in Figs. 137 and 138 represent the various valve events throughout a complete revolution of the wheels. Comparison between corresponding diagrams in the figures shows

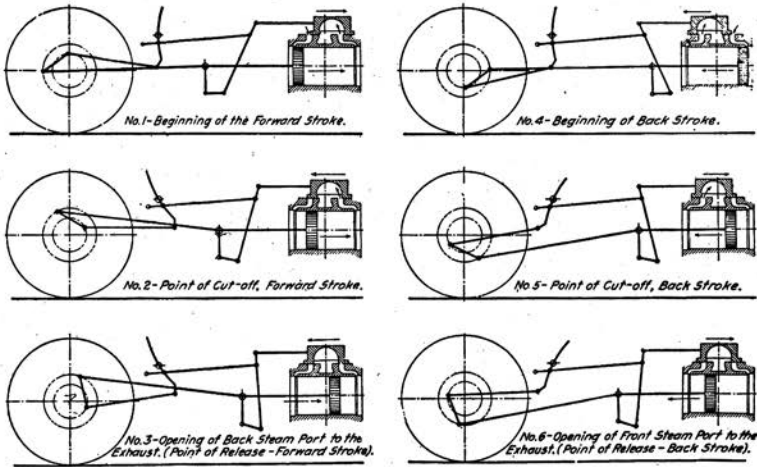

FIG. 137.—Walschaert gear and outside admission valve. Various important positions during revolution.

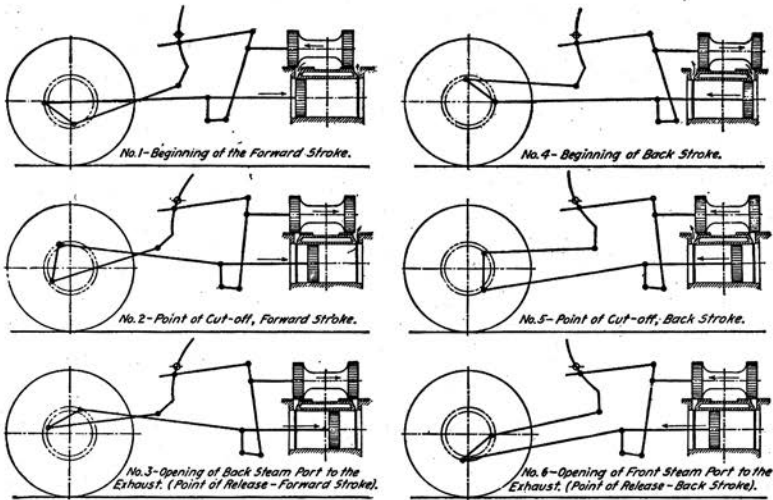

FIG. 138.—Walschaert gear and inside admission valve. Various important positions during revolution.

clearly the difference in the arrangement of the Walschaert valve gear for *outside* and *inside* admission valves.

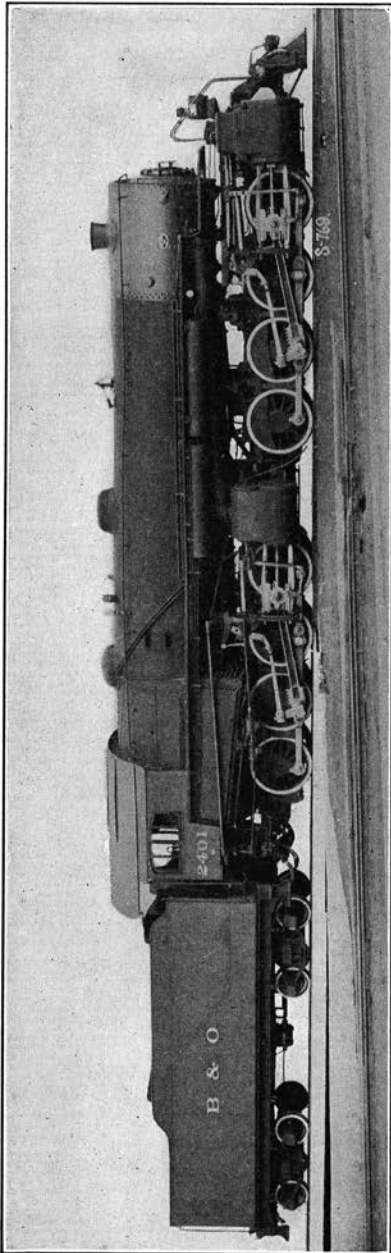

FIG. 139.—Mallet articulated compound locomotive with Walschaert valve gears.

Fig. 139 shows a Mallet articulated compound locomotive equipped with the Walschaert gear. An interesting feature of this engine is that the forward cylinders, which are the low pressure, have flat valves admitting steam outside, while the rear cylinders, the high pressure, have piston valves admitting steam inside.

The general arrangement of the Walschaert valve gear depends largely on the general design of the locomotive. The proper lengths of the arms of the lap and lead lever for any desired lap and lead may be determined by the relationship:

$$\frac{S}{2C} = \frac{L}{V}$$

in which

S = length of stroke
(see Fig. 140.)

V = distance from
valve stem to
radius rod con-
nection.

L = distance from
radius rod con-
nection to bot-
tom connection.

C = lap plus lead.

It has been seen that with the Walschaert gear the valve receives motion from two different sources,

the eccentric crank and the cross-head. For a rough analysis of the motion, it is convenient to determine some equivalent eccentric which acting alone would move the valve the same as it is moved by the combined action of the eccentric crank and cross-head.

In Fig. 136, Og represents the link of the Walschaert gear in its mid-position, the trunnion being at O . The dotted line Og' represents the link at some other time in the stroke. The

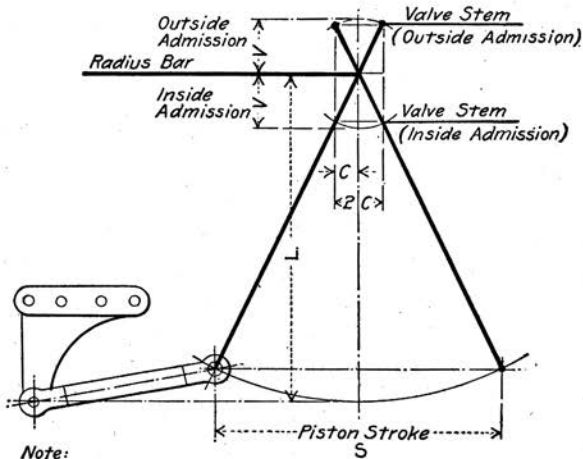

Note:
Lap and Lead Lever
Connector to Stand
Horizontal at Center
of Stroke.

FIG. 140.—Lap and lead lever.

points g and g' indicate the positions of the block, and K and K' the end of the eccentric rod. The block attached to the radius rod is displaced the distance b and this displacement, slightly affected by angularity, is transmitted to the pin F connecting the radius rod with the lap and lead lever.

The movement of the link to the dotted position is caused by a crank rotation through some angle θ which causes the eccentric center to move horizontally through the distance $r \sin \theta$ and, neglecting angularity, the horizontal movement of F is $r \sin \theta \frac{Og}{OK}$, where Og and OK are straight-line measurements. Imagining the cross-head to be stationary,

the movement received by the valve from the eccentric is $r \sin \theta \frac{Og}{OK} \frac{(L - V)}{L}$.

In Fig. 141 draw any crank position and lay off OE_1 as shown, equal in length to $r \cdot \frac{Og}{OK} \frac{(L - V)}{L}$. Then $Os = r \sin \theta \frac{Og}{OK} \frac{(L - V)}{L}$ and OE_1 is the simple eccentric which is equivalent to the mechanism operated by the eccentric crank when the radius rod is in the position shown in Fig. 136. If the block is above the trunnion of the link, OE_1 should be laid off in the opposite direction in Fig. 141.

Besides the motion received from the eccentric crank, through the link, the valve receives motion from the cross-head through

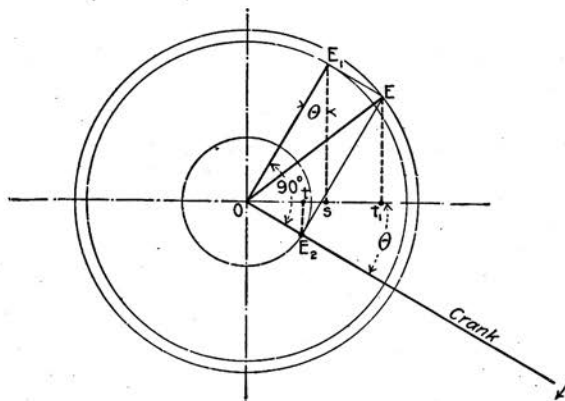

FIG. 141.—Development of equivalent eccentric for Walschaert gear.

the lap and lead lever. When the crank has moved through the angle θ the point m (Fig. 136) is displaced from mid-position a distance $R \cos \theta$, which is modified to $R \cos \theta \frac{V}{L}$ at the valve. This movement could be obtained from an eccentric OE_2 (Fig. 141) set in line with the crank, where $OE_2 = R \frac{V}{L}$; then $Ot = R \cos \theta \frac{V}{L}$ = horizontal displacement of the valve due to the movement of the lap and lead lever. If an outside admission valve is used OE_2 should be drawn on the other side of the shaft from the crank.

It will be seen that when the cross-head is at the middle of its stroke, which will be when θ is 90° if angularity is neglected,

the valve receives its motion from the link mechanism, represented by the equivalent eccentric OE_1 , and Ot is zero. Also, when the cross-head is at one end of its stroke the distance Ot will be a maximum and O_s zero, meaning that the valve receives its motion from the cross-head. By drawing E_1E equal and parallel to OE_2 , $st_1 = Ot$, and $Ot_1 = O_s + Ot$. Therefore OE represents the single equivalent eccentric which would produce the same valve displacement as OE_1 and OE_2 combined.

It must be clearly understood that the use of an equivalent eccentric gives only the approximate valve motion and neglects any distortions due to angularity of the rods. In design work or careful analysis, it is necessary to lay out the gear very accurately on the drawing board and follow the various parts through a complete revolution to determine the exact movement of the valve. This should be done for at least two cut-offs, the latest one and the one at which the engine will be operated most of the time.

In laying out the gear the following proportions represent good practice:

Radius rod length at least 8 times the travel of the link block, 10 or 12 is better.

Eccentric rod length at least $3\frac{1}{2}$ times the eccentric throw; should be as long as circumstances will permit with practically equal lengths of radius rod and eccentric rod.

Angle of swing of link should not be more than 45° .

Angle of oscillation of lap and lead lever, 45° to 50° is good; it should always be less than 60° .

The Walschaert valve gear can be designed to give a variable lead. This practice has been followed recently in a number of cases. With a variable lead the longest possible cut-off in starting can be obtained, combined with the proper amount of lead at the ordinary running cut-off. In the case of passenger locomotives particularly, a steam distribution like this is often most desirable. The favorable results for starting are obtained, however, at the expense of the distortion of the valve events in the back motion. For this reason, the Walschaert valve gear with variable lead is suitable only for passenger and fast freight locomotives, and not for slow freight and switching locomotives.

With a variable lead so arranged that the lead increases as the reverse lever is hooked up, the eccentric crank lags behind the correct position for a constant lead; in other words, it is

so set that the link is not in its central position when the crank pin is on center.

The Joy Valve Gear.—Fig. 142 shows a reversing gear, credited to David Joy, in which the use of an eccentric has been avoided altogether. The whole movement is derived from a point, *a*, near the middle of the connecting rod. Point *d* is fixed on the frame of the engine and *k* moves in an arc with *d* as a center, while points *a* and *b* trace oval curves as indicated in the figure, the major axis of the larger oval being equal to the stroke of the piston. As the point *b* traces its curve, point *e* slides up and

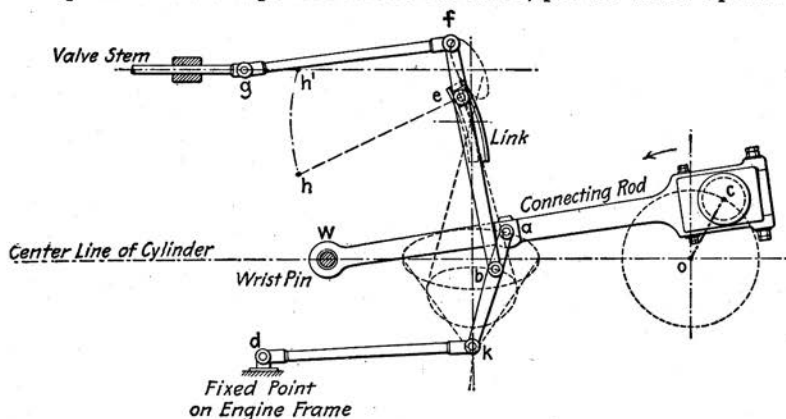

FIG. 142.—Joy valve gear.

down in the curved guide or link. The point *f* of the rod *feb* traces an approximate ellipse, and the travel of the valve is equal to the distance between two lines drawn perpendicular to the line of motion of the valve and tangent to the ellipse on either side.

A change in the inclination of the link cause a change in the shape of the ellipse at *f* and a change in the valve travel and steam distribution. If the link is turned to the other side of the vertical axis, the engine will be reversed.

Sometimes instead of the link a radius rod, *he*, is used, with *h* a movable point which can be held fixed in any desired position on the path *hh'*. The same effect as shifting the link is then obtained by shifting the point *h* thus changing the center of the arc in which *e* moves.

The equivalent eccentric can be found for any position of the link. The method is illustrated in Fig. 143, in which OE_1 is

laid off along the crank line equal in length to $\frac{fe}{eb} \cdot \frac{bk}{ak} \cdot OC$, and E_1E_2 is perpendicular to OE_1 and equal to $\left(1 + \frac{fe}{eb}\right) \frac{Wa}{WC} OC \cdot \tan \alpha$, in which α is the angle of inclination of the link. The equivalent eccentric for the position of the link corresponding to the angle α is OE_2 .

The validity of this construction can be proven by means of a skeleton diagram of the mechanism as shown in Fig. 144. The curved link or guide for the point e has been modified into

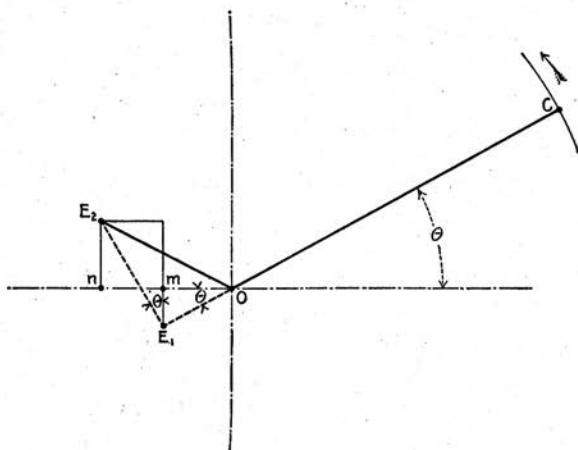

FIG. 143.—Equivalent eccentric for Joy valve gear.

a straight line and represented by AA . It is further assumed that the rod fg , connected to the valve stem, has no angular vibration, *i.e.*, that the point g has the same movement as f . OF is laid off equal to aC and a line is drawn through F perpendicular to OW ; this line will pass through the fulcrum of the link. If the pin at C were removed and the end of the connecting rod brought to O , a would coincide with F , and the points f , e , a , b , k would fall on the vertical dotted line through F .

Except for the effect of angularity, a receives the same horizontal movement as W . The point k travels on an arc and the combined movements of the points k and a counteract the distortions due to angularity, so that the horizontal movement of the point b is almost perfectly harmonic. This being the case we may neglect the angularity of WC and assume that k travels

in a straight line; then the horizontal displacement of the point b , from the line through F , is given by the expression

$$h_1 = \frac{bk}{ak} OC \cdot \cos \theta$$

The vertical displacement of a is equal to the vertical movement of C multiplied by the ratio $\frac{Wa}{WC}$. The distortions due to the angularity of the rod feb pivoted at e practically counteract those of the rod ka pivoted at k , because they are opposite

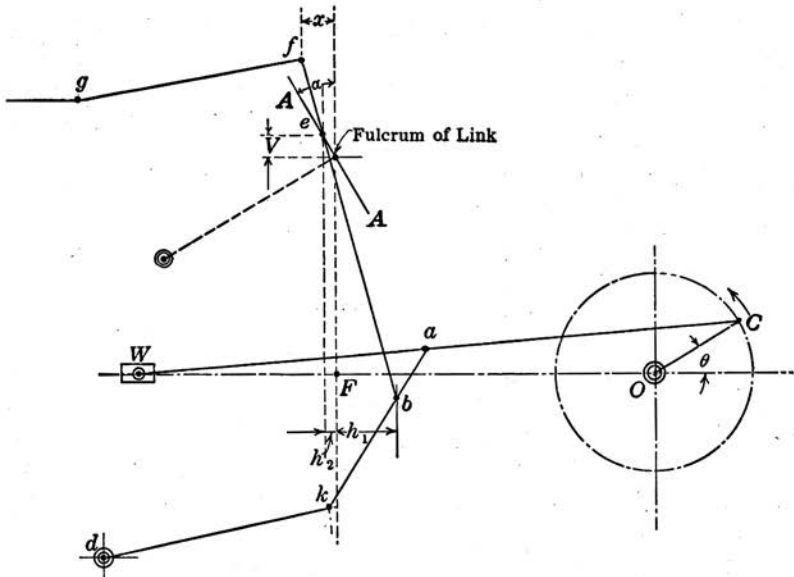

FIG. 144.—Skeleton diagram of Joy valve gear.

in direction. The vertical displacement of the point e from the fulcrum of the link can then be written:

$$v = \frac{Wa}{WC} OC \sin \theta$$

On account of the path over which e travels being inclined from the vertical, the movement of e along that path causes e to be displaced horizontally as well as vertically. This horizontal movement is equal to $v \tan \alpha$, or

$$h_2 = \frac{Wa}{WC} OC \sin \theta \tan \alpha$$

and must be added to h_1 to give the total horizontal movement of the point b ;

$$h_1 + h_2 = \frac{bk}{ak} OC \cos \theta + \frac{Wa}{WC} OC \sin \theta \tan \alpha$$

The horizontal movement of the point f will be

$$\begin{aligned} X &= h_2 + (h_1 + h_2) \frac{fe}{eb} = \left(1 + \frac{fe}{eb}\right) h_2 + \frac{fe}{eb} h_1 \\ &= \left(1 + \frac{fe}{eb}\right) \frac{Wa}{WC} OC \sin \theta \tan \alpha + \frac{fe}{eb} \cdot \frac{bk}{ak} OC \cos \theta \end{aligned}$$

In Fig. 143, $Om = OE_1 \cos \theta$

$$= \frac{fe}{eb} \cdot \frac{bk}{ak} \cdot OC \cos \theta$$

and $mn = E_1 E_2 \sin \theta$

$$= \left(1 + \frac{fe}{eb}\right) \frac{Wa}{WC} OC \tan \alpha \sin \theta$$

Therefore $On = X$

and this movement can be secured from an eccentric OE_2 set as shown in the figure. Hence the equivalent eccentric for the gear is OE_2 .

PROBLEM 15

In Fig. 144 take $OC = 12''$, $Ca = 4' 0''$, $aW = 3' 0''$, $ab = 7''$, $bk = 12''$, $dk = 2' 0''$; perpendicular distance of d from $WO = 1' 7''$, horizontal distance of d from $O = 6' 0''$; $bf = 2' 0''$, $ef = 3''$, $fg = 3' 6''$; radius of link $2' 0''$, center of curvature of link $7''$ above WO and $5' 11''$ to the left of O .

Find (1) horizontal movement of b .

(2) vertical movement of b .

(3) travel of valve and angle of advance of equivalent eccentric.